

**Conceito**

Centralização da utilização dos serviços da cozinha  
Fácil Montagem  
Flexibilidade na escolha dos componentes da cozinha

**Utilização**

Uso previsto para 40 à 50 pessoas por cozinha  
Capacidade total de abastecimento do conjunto: 250 pessoas  
Permanência no local de montagem: 6 meses a um ano  
Restrição de durabilidade: lona - dois anos

**Materiais**

Chapas de aço 0,48 mm  
Polipropileno 25mm  
PVC 1mm  
Lona impermeável  
Alumínio para estrutura da lona - mastros  
Concreto Armado para base  
Fios de aço - tracionáveis  
Eletrodomésticos utilizados: cooktop, freezer horizontal / gavetas refrigeradas, forno industrial microondas comum  
Equipamento com caixa de água e bomba

**Segurança**

Grelha em frente ao fogão, separação da parte elétrica por material isolante, Piso Anti-derrapante, isolamento térmico das placas que compõe a cozinha

**Transporte**

conjunto de seis módulos de cozinha - 22 caixas de transporte mais duas caixas auxiliares

**Abastecimento**

passagem das instalações h idráulicas previstas sob o piso elevado

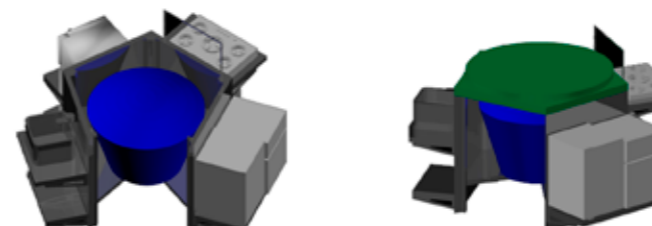
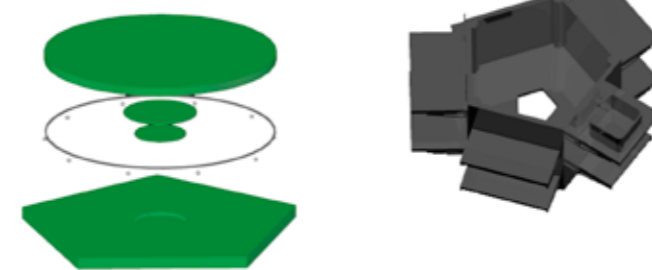
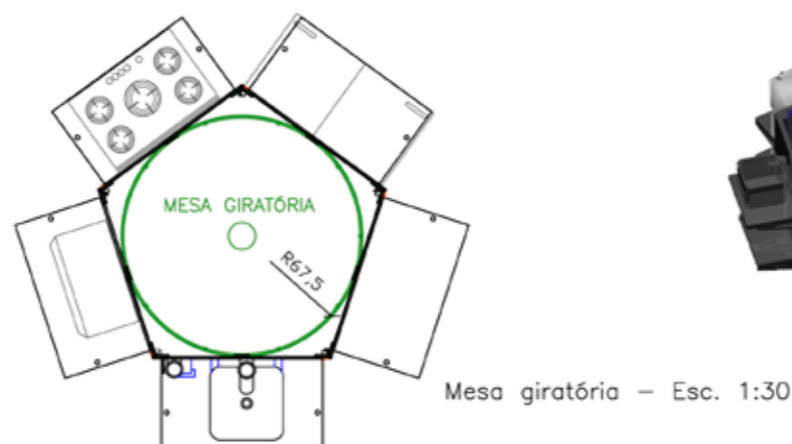
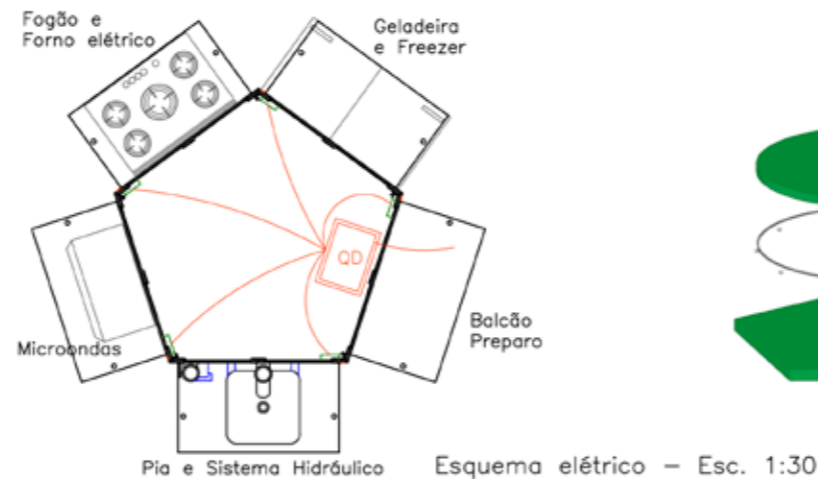
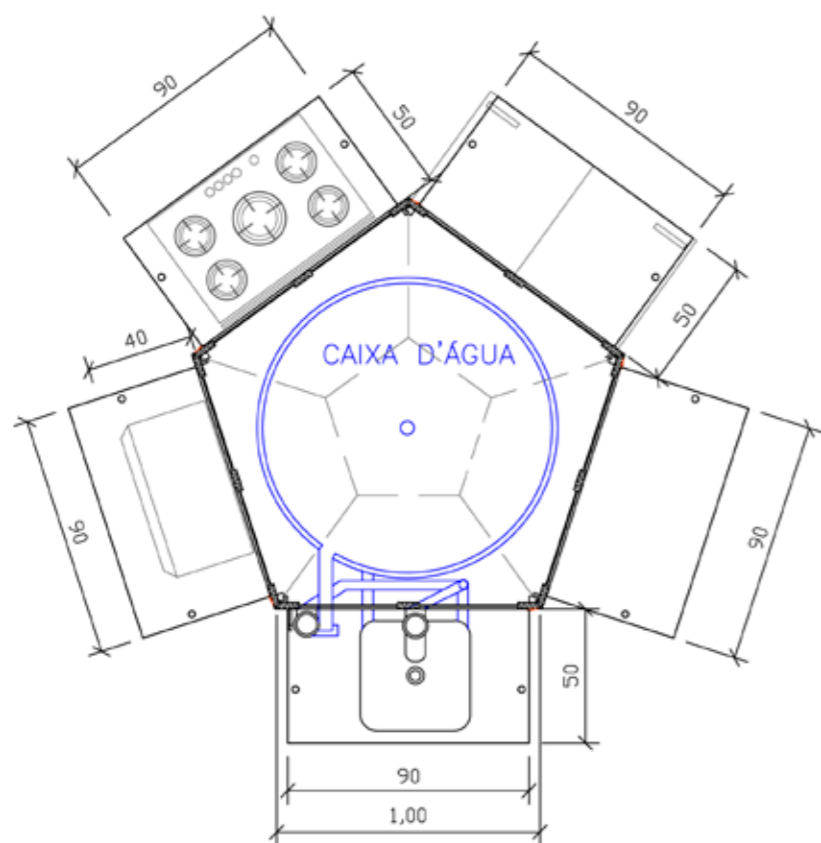

Modelo Eletrônico do módulo de cozinha

Planta equipamento - Cozinha - Esc. 1:20

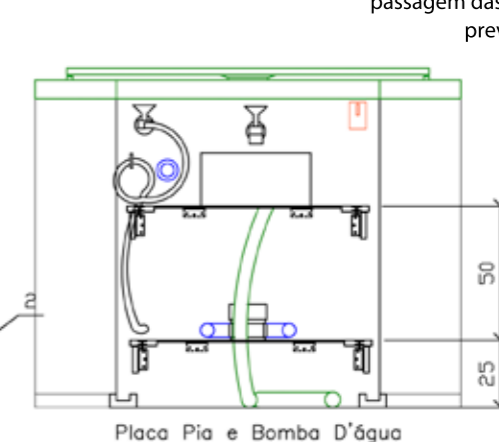
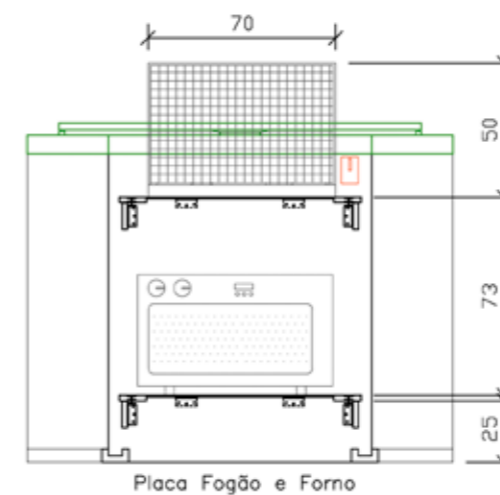
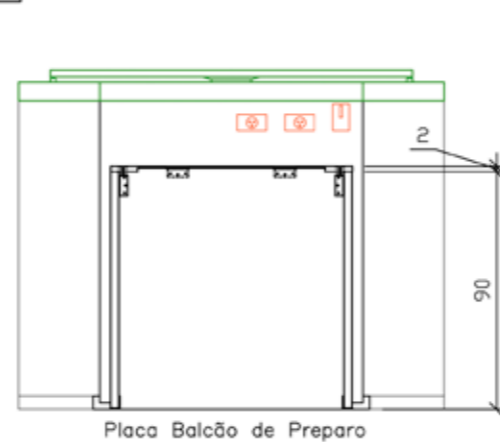
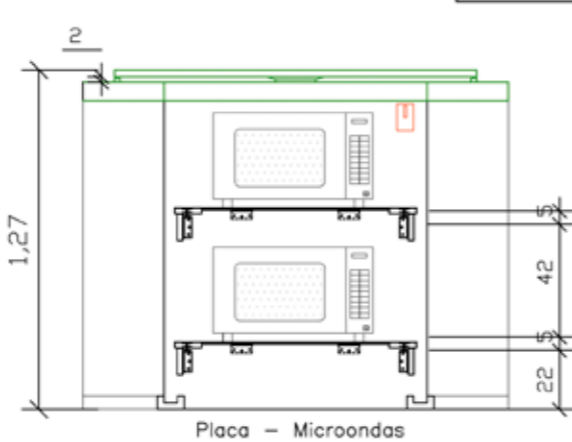
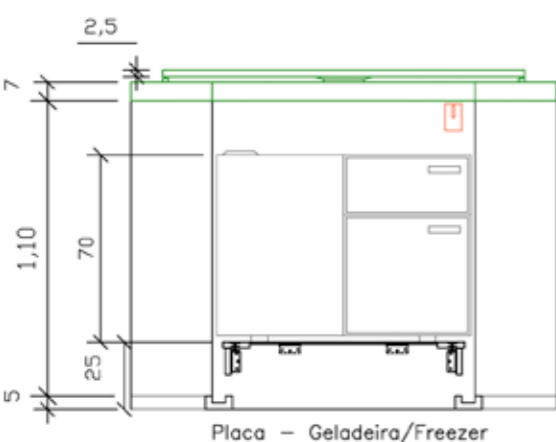

Vistas Frontais - Placas - Esc. 1:20

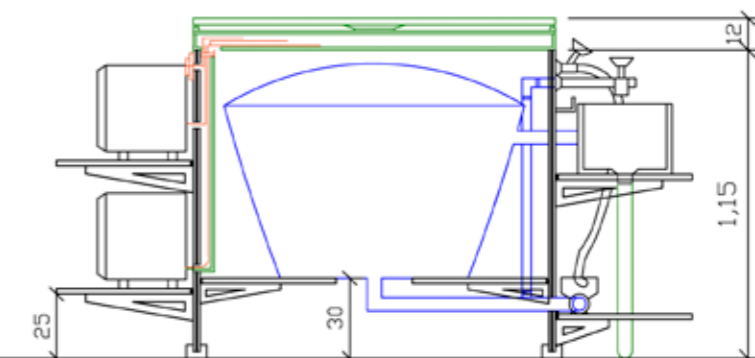
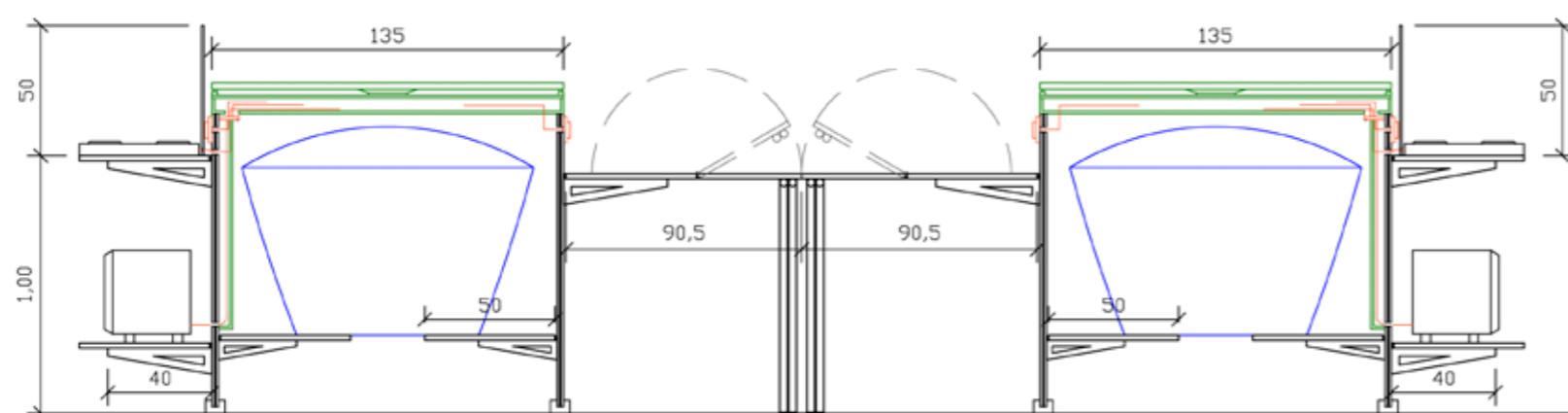

Corte equipamentos acoplados - Esc. 1:20

Corte equipamento simples - Esc. 1:20

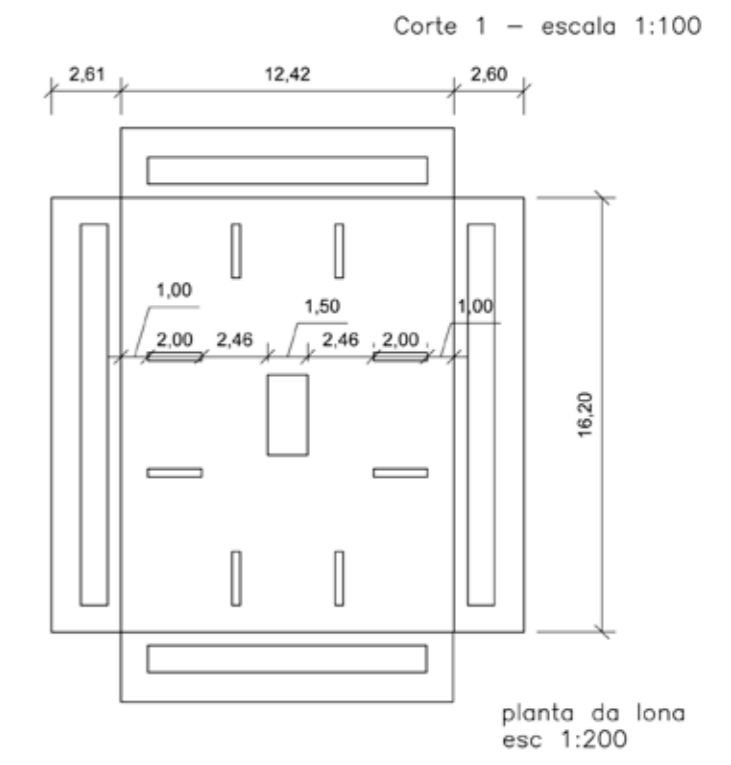
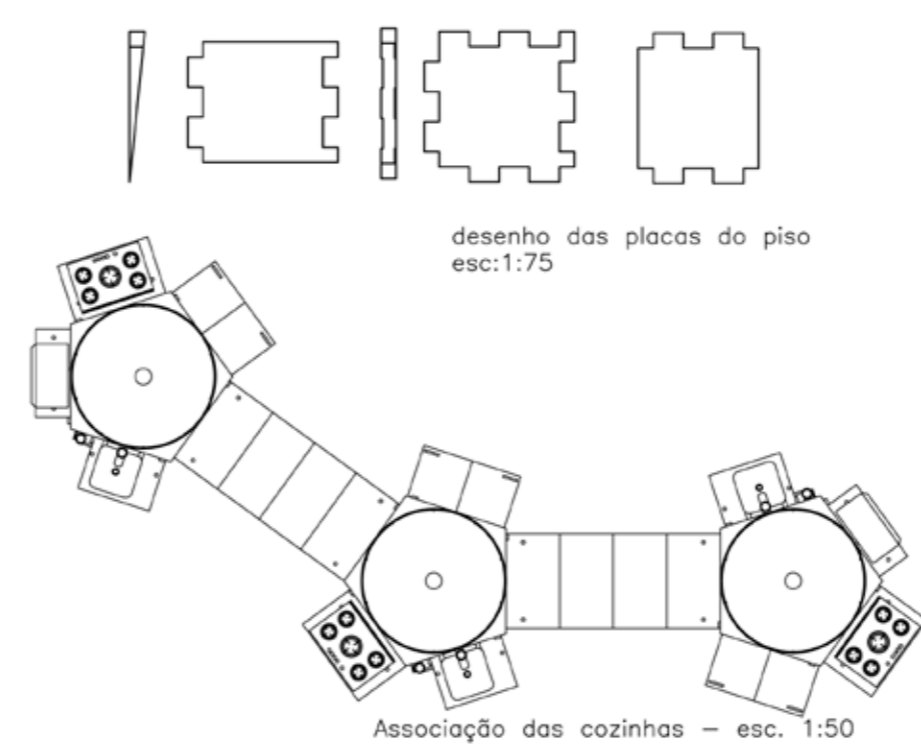
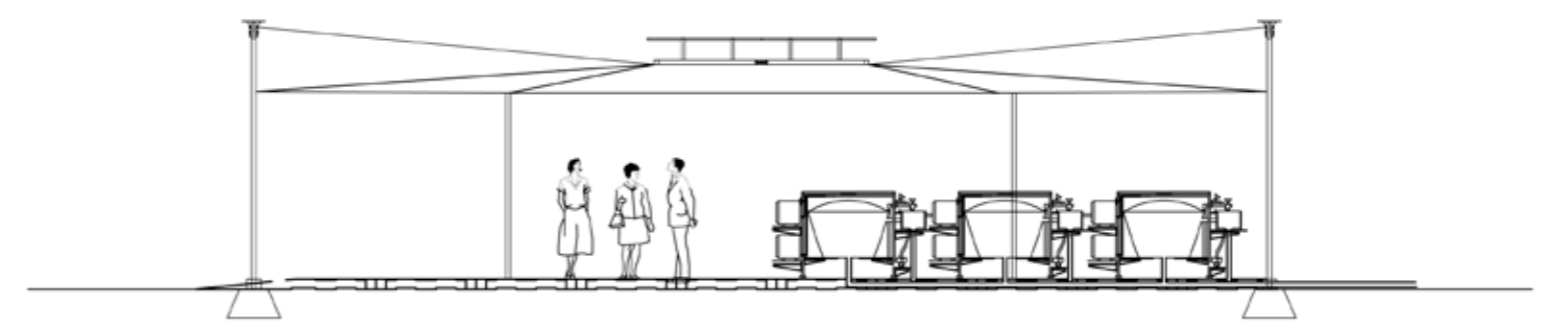
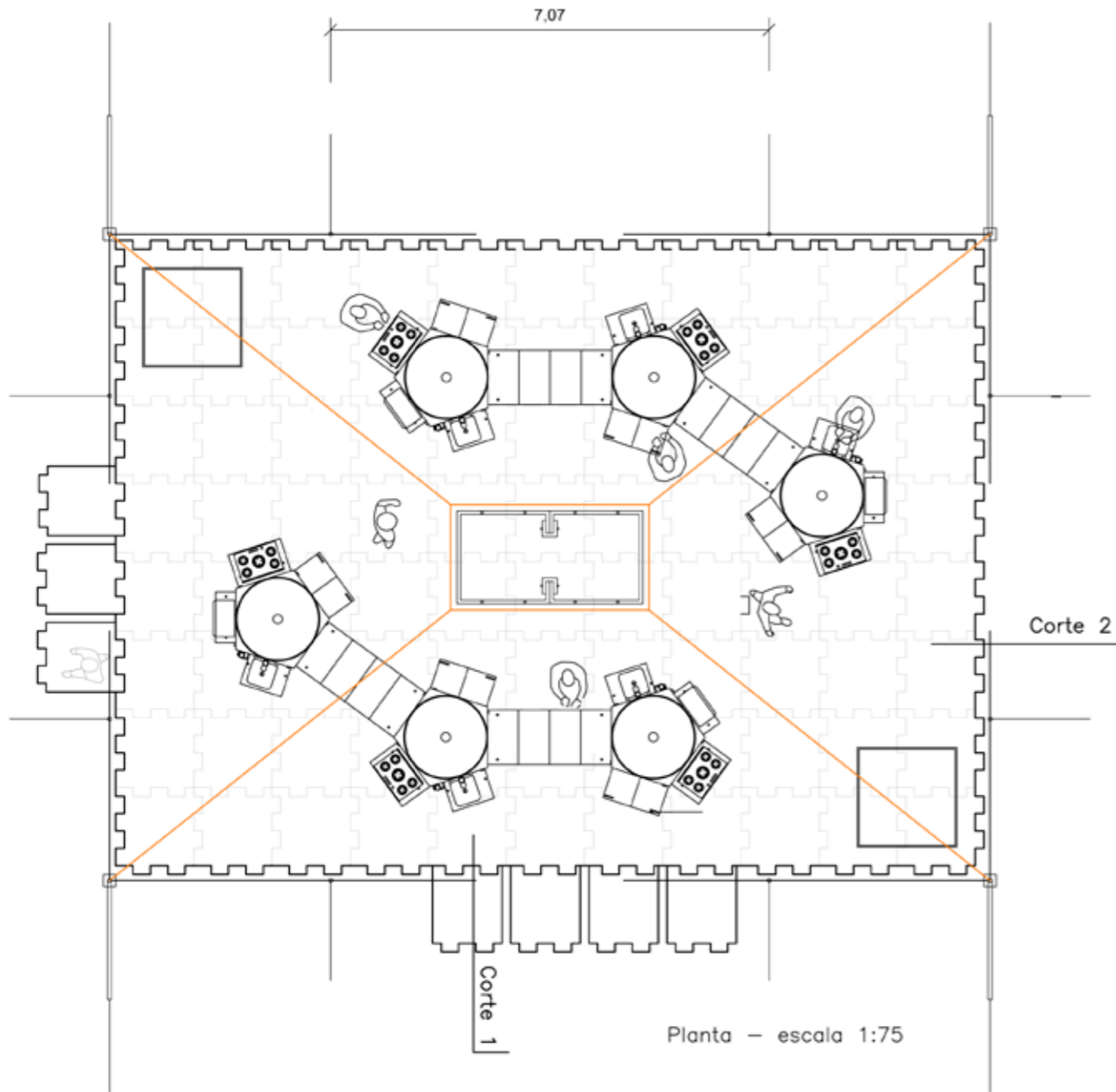
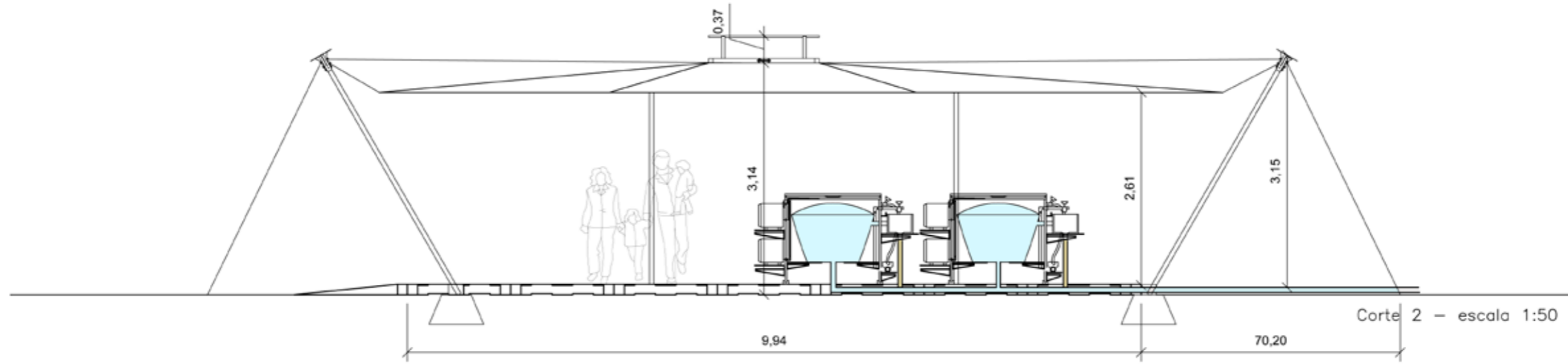

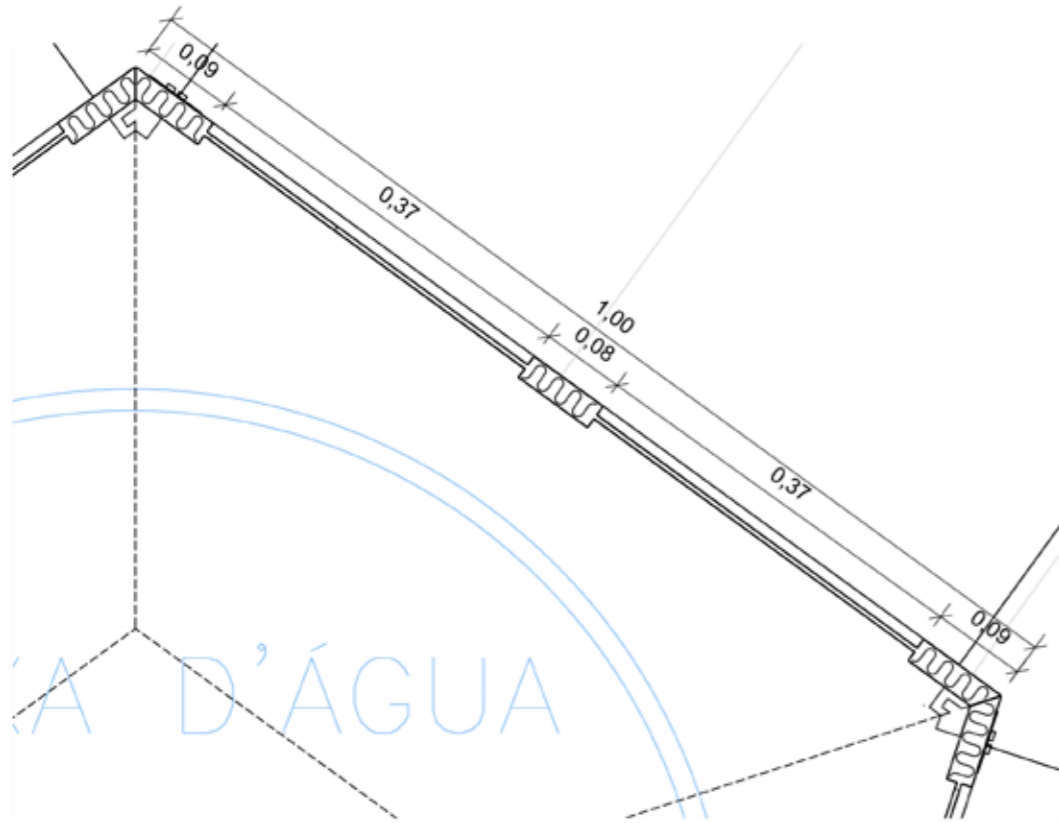

Encaixe das placas do módulo da cozinha – chapas de aço dobradas com encaixes para mão francesa e interior de lã de rocha. Encaixe tipo macho fêmea entre placas. Ao lado, detalhe da mão-francesa aberta e trava.

Detalhe Cozinha  
esc. 1:5

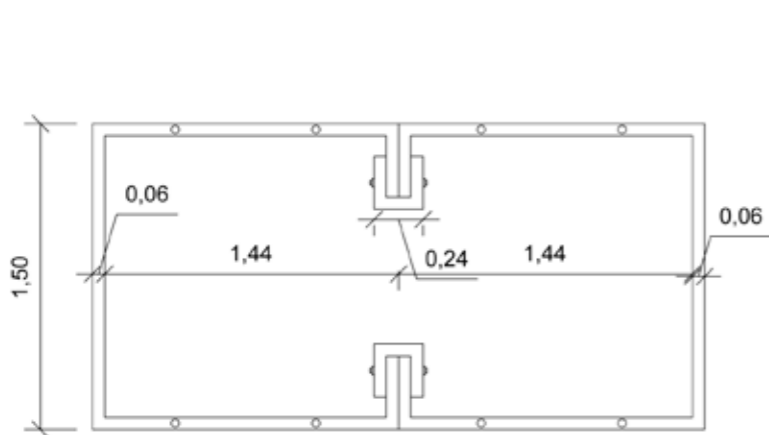
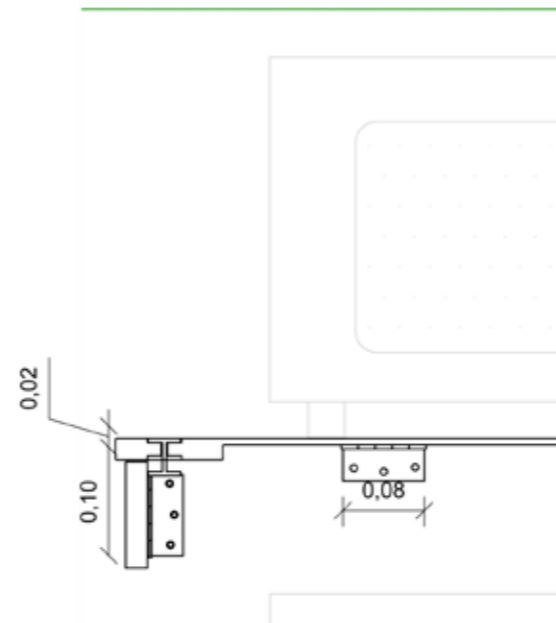

Detalhe da Peça central de Tração  
esc. 1:20 e 1:5

Dois peças separadas, metálicas, unidas por uma peça em formato de U, parafuzada que também sofre tração.

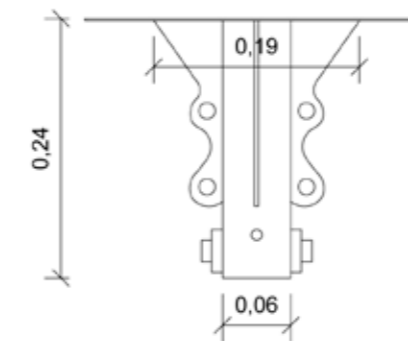
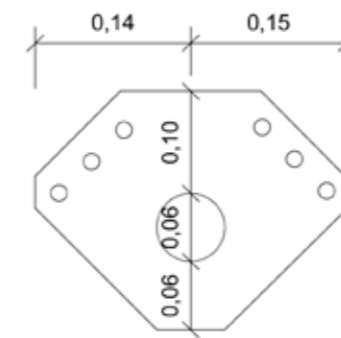
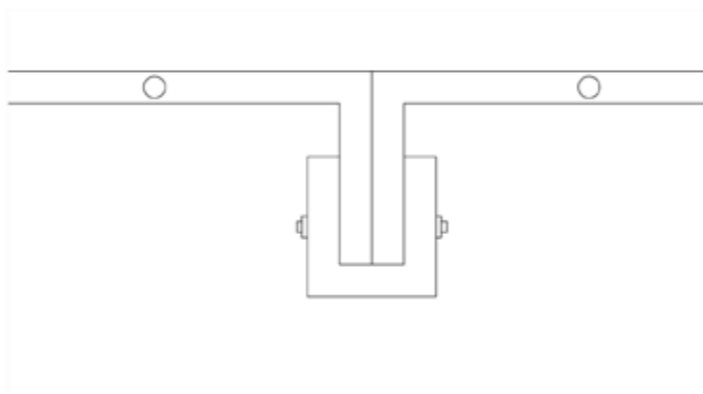
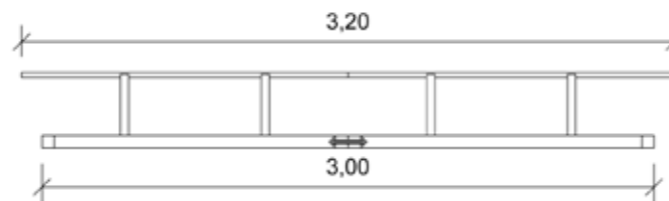

Detalhe Mastro  
esc. 1:5

Peças de topo do mastro, para a colocação, por mosquetão, dos cabos de tração e também para a amarração da lona. Peças parafuzadas.

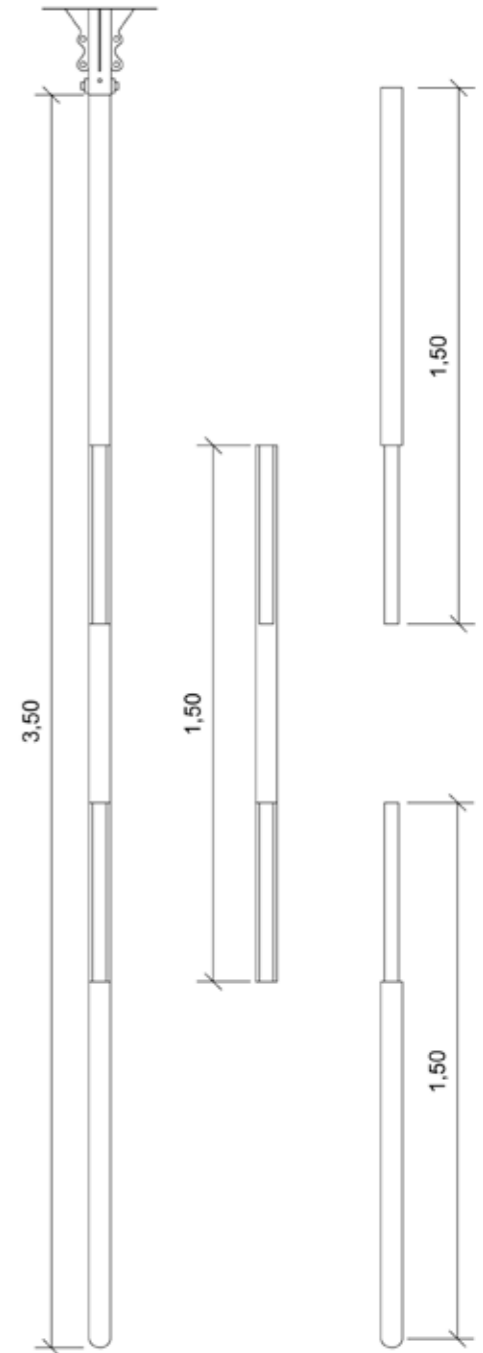

Detalhe Mastro  
esc. 1:15

Três peças que compõem o mastro, encaixes longitudinais tipo macho fêmea.



